

TOP VIEW

STAINLESS STEEL MOUNTING BUTTON

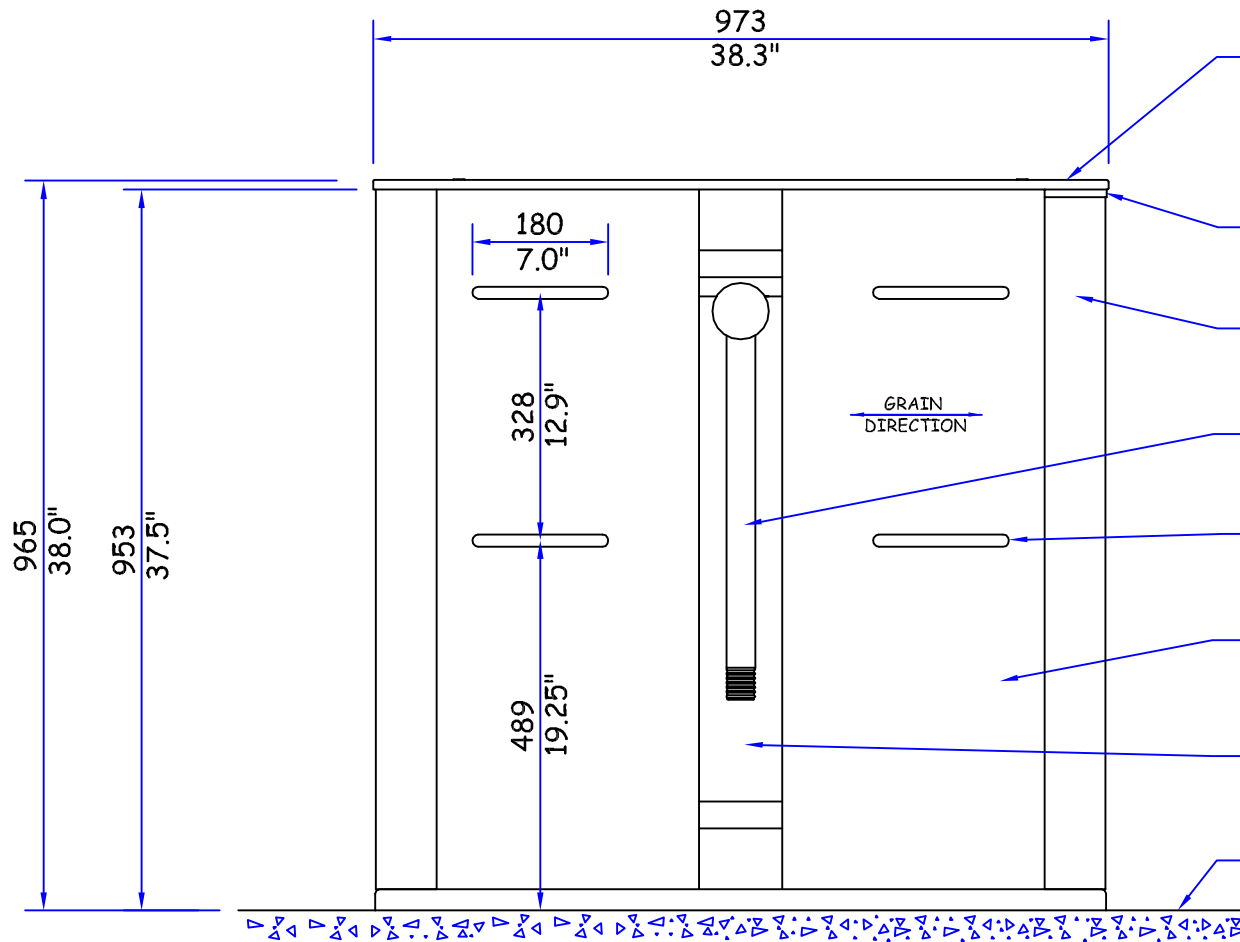

SIDE VIEW

DECORATIVE TOP - WHITE TOUGHENED GLASS - CONFORMS TO EN12150 & EN12600

LANE STATUS INDICATOR - CLEAR FROSTED ACRYLIC

STAINLESS STEEL END - 240 GRIT - HORIZONTAL GRAIN

BREAKAWAY BARRIER ARM - BRUSHED ALUMINIUM

INFRA-RED WINDOW - GLOSS BLACK ACRYLIC

STAINLESS STEEL SIDE PANEL 240 GRIT - HORIZONTAL GRAIN

ARM RECESS - GLOSS BLACK ACRYLIC

FINISHED FLOOR LEVEL

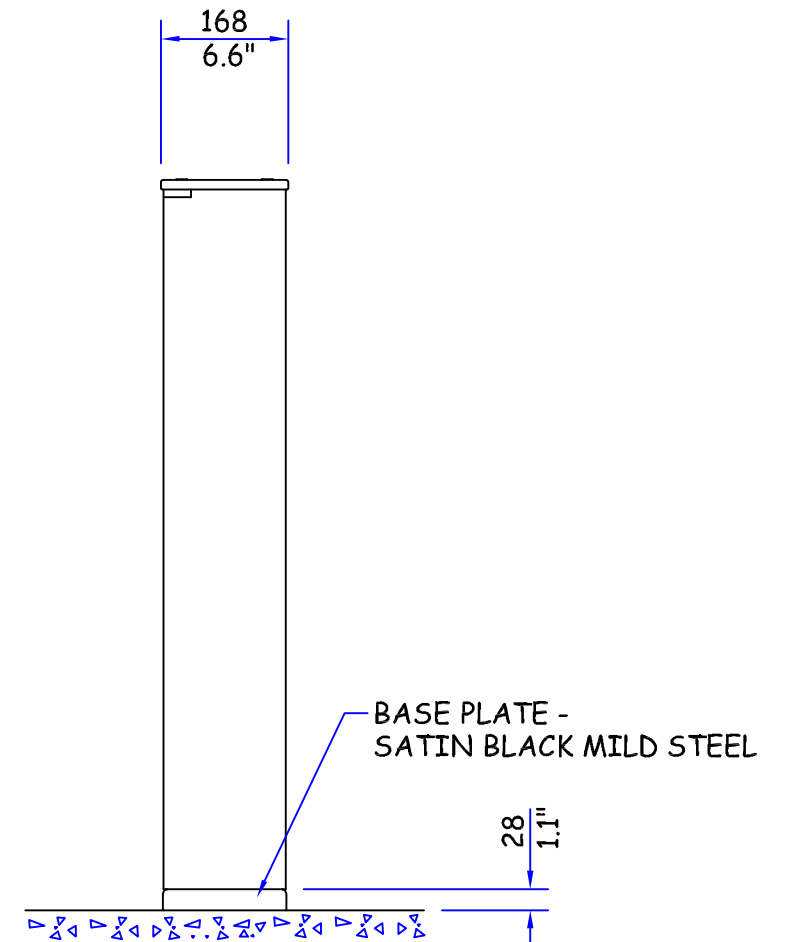

END VIEW

BASE PLATE - SATIN BLACK MILD STEEL

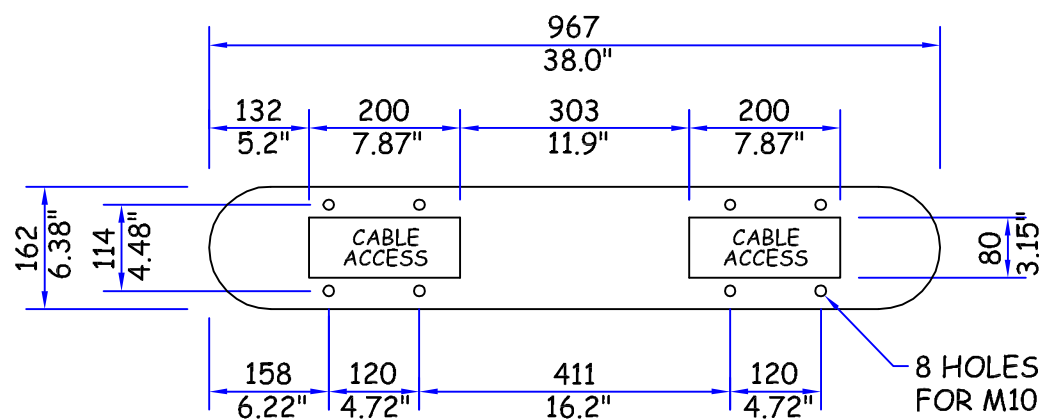

BASEPLATE VIEW

8 HOLES 14 DIA (0.55") FOR M10 (3/8") FIXINGS SUITABLE FOR FLOOR

PRODUCT: FASTLANE PLUS R30		
TITLE: GENERAL DIMENSIONS		
DRAWN: DSC	DRAWING No: S665_520_A1	
DATE: 22.4.08	This document is the copyright of Integrated Design Ltd	

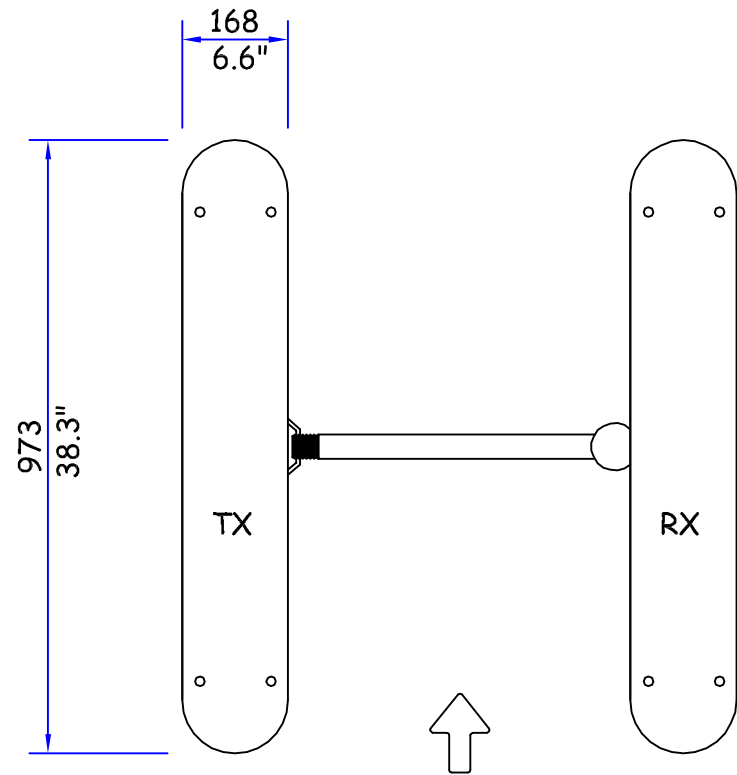

STANDARD LANE WIDTH
PEDESTRIAN ACCESS

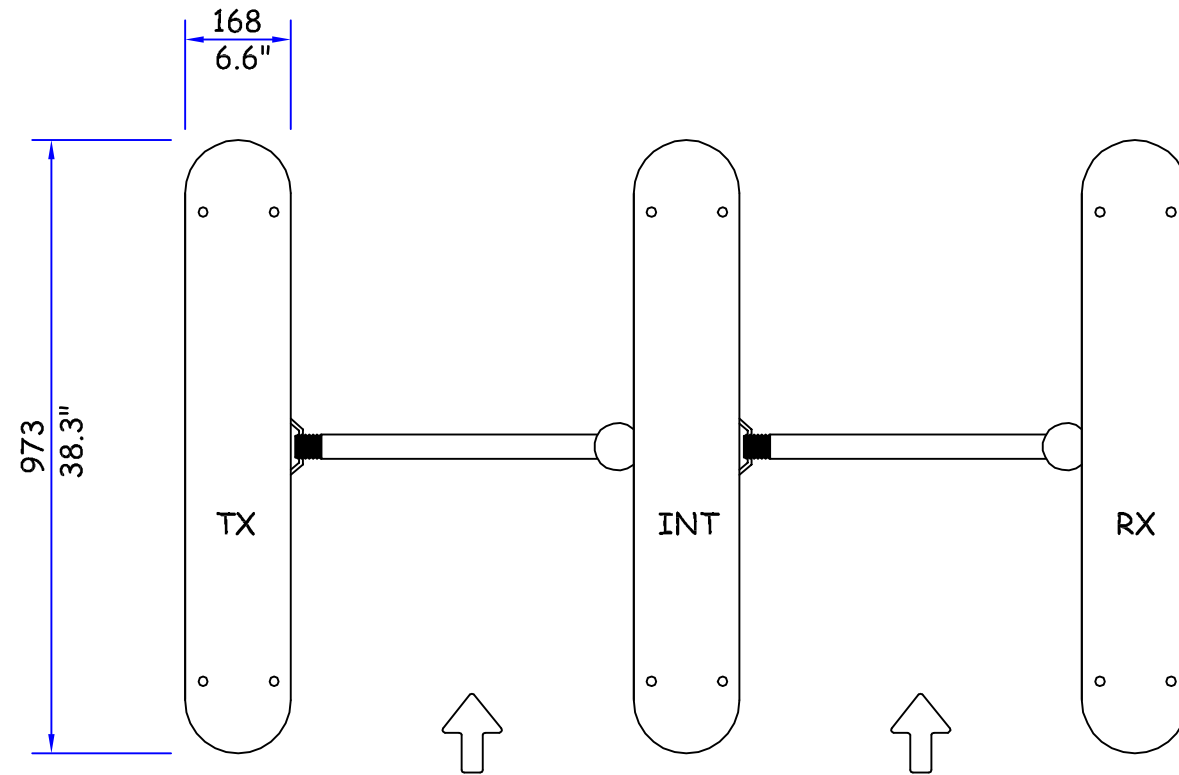

STANDARD LANE WIDTH
PEDESTRIAN ACCESS

STANDARD LANE WIDTH
PEDESTRIAN ACCESS

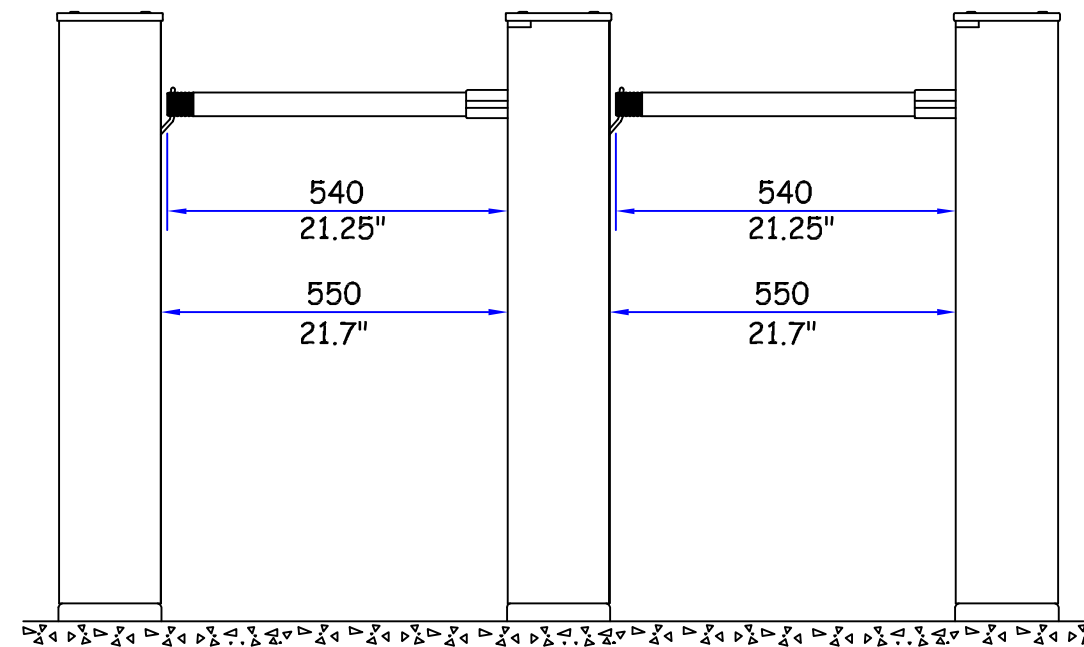
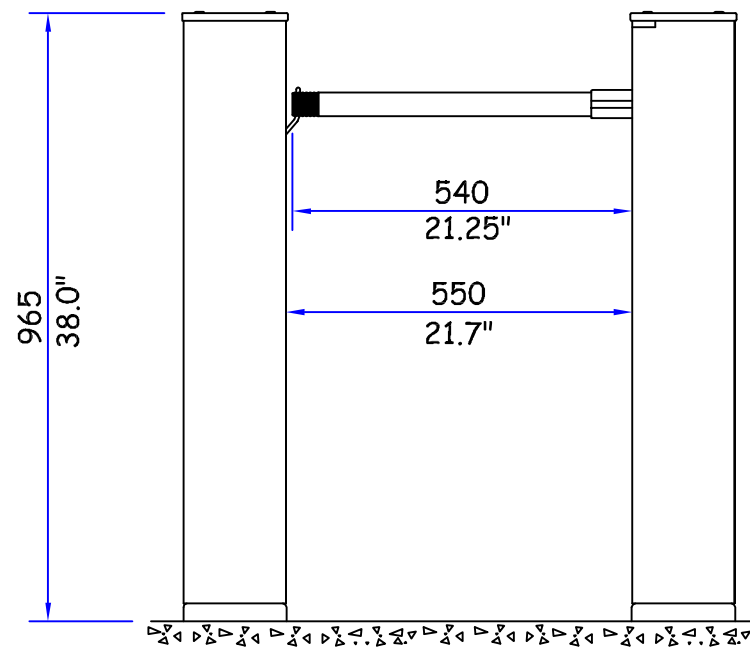

PRODUCT: FASTLANE PLUS R30	
TITLE: GENERAL LAYOUT	
DRAWN: DSC	DRAWING No: S665_521_A2
DATE: 22.4.08	This document is the copyright of Integrated Design Ltd

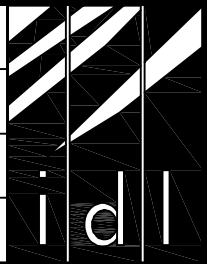

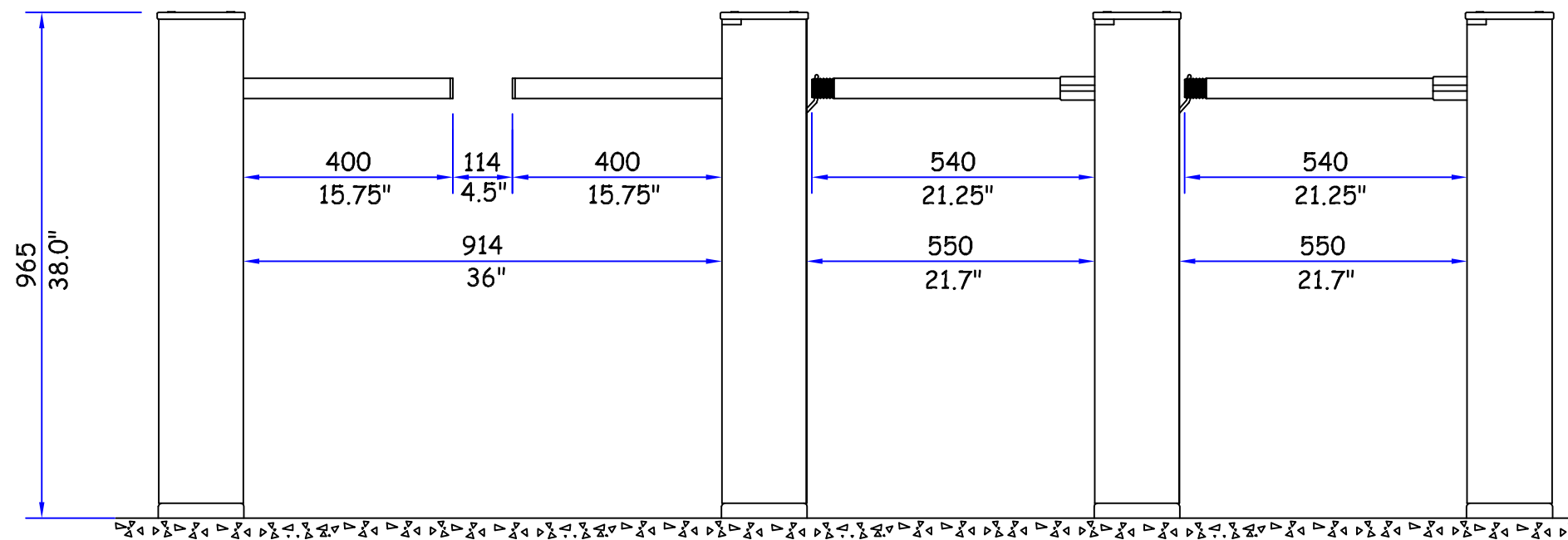
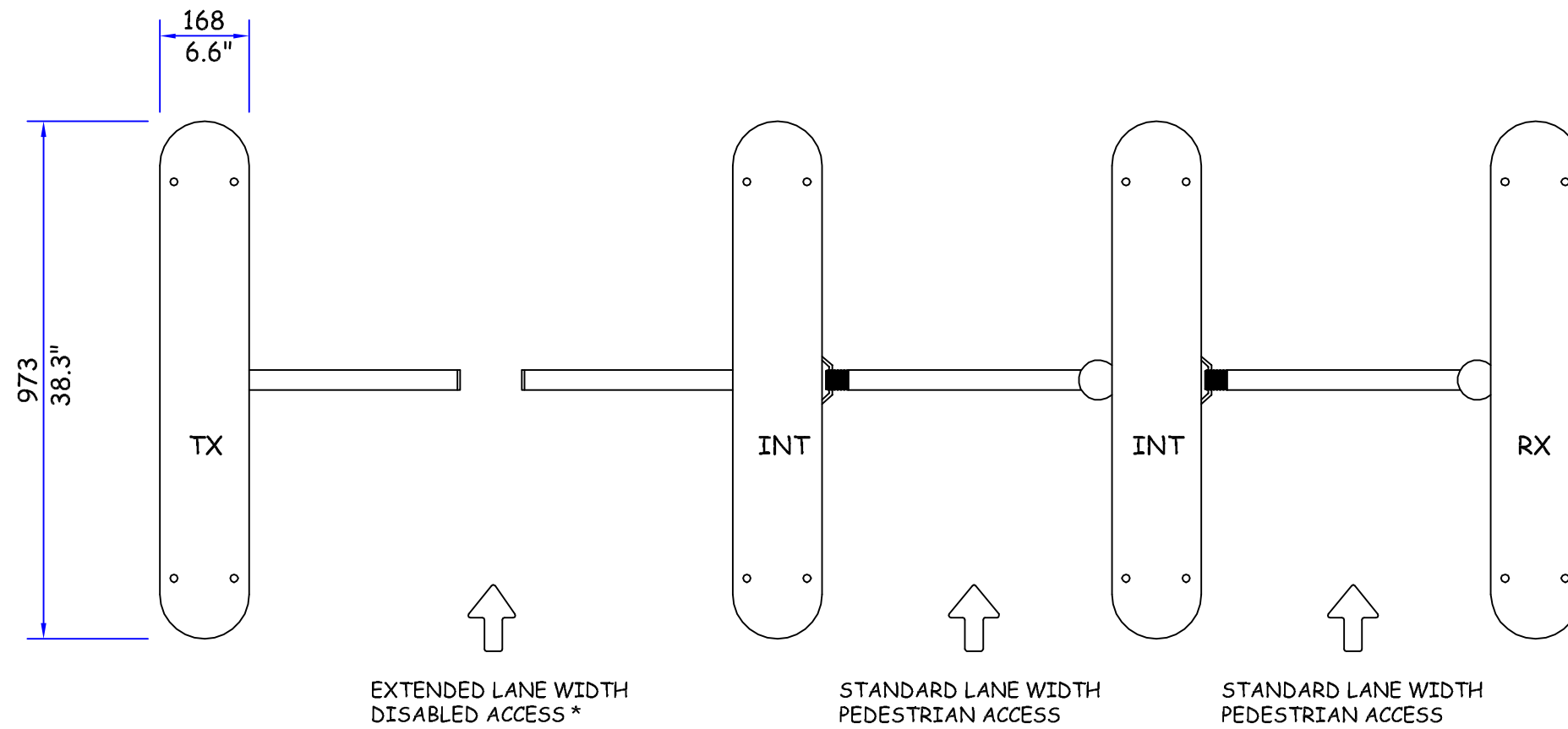

* SUBJECT TO LOCAL LEGISLATION

PRODUCT: FASTLANE PLUS R30		
TITLE: GENERAL LAYOUT		
DRAWN: DSC	DRAWING No: S665_522_A2	
DATE: 22.4.08	This document is the copyright of Integrated Design Ltd	

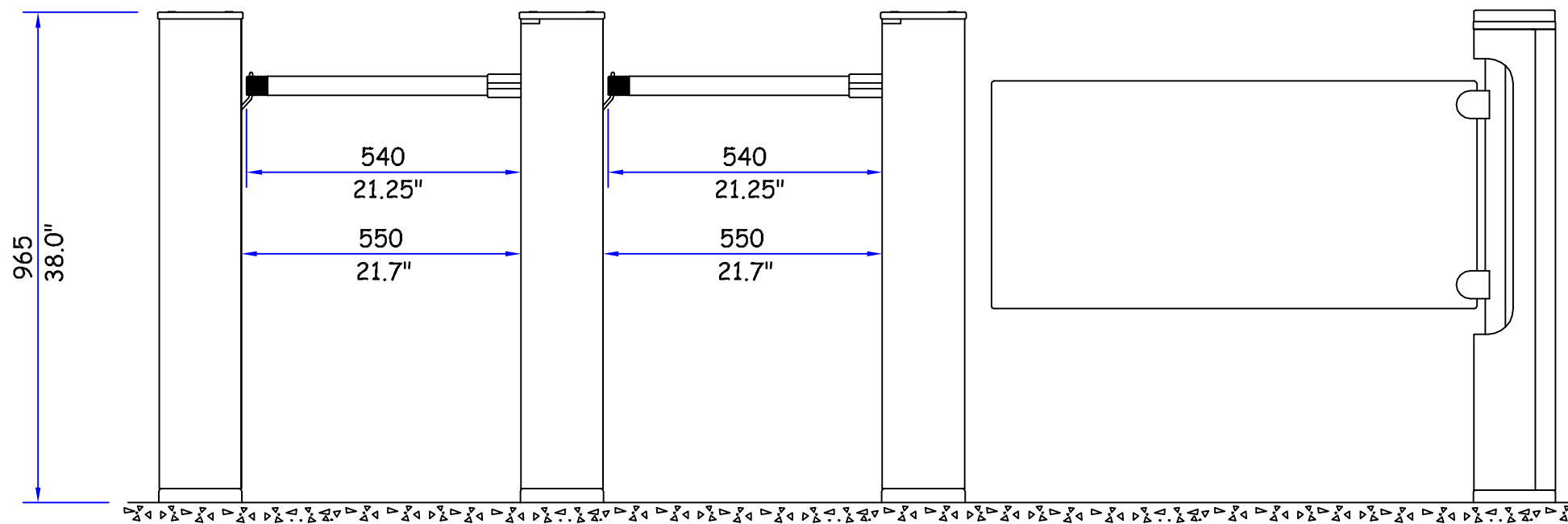
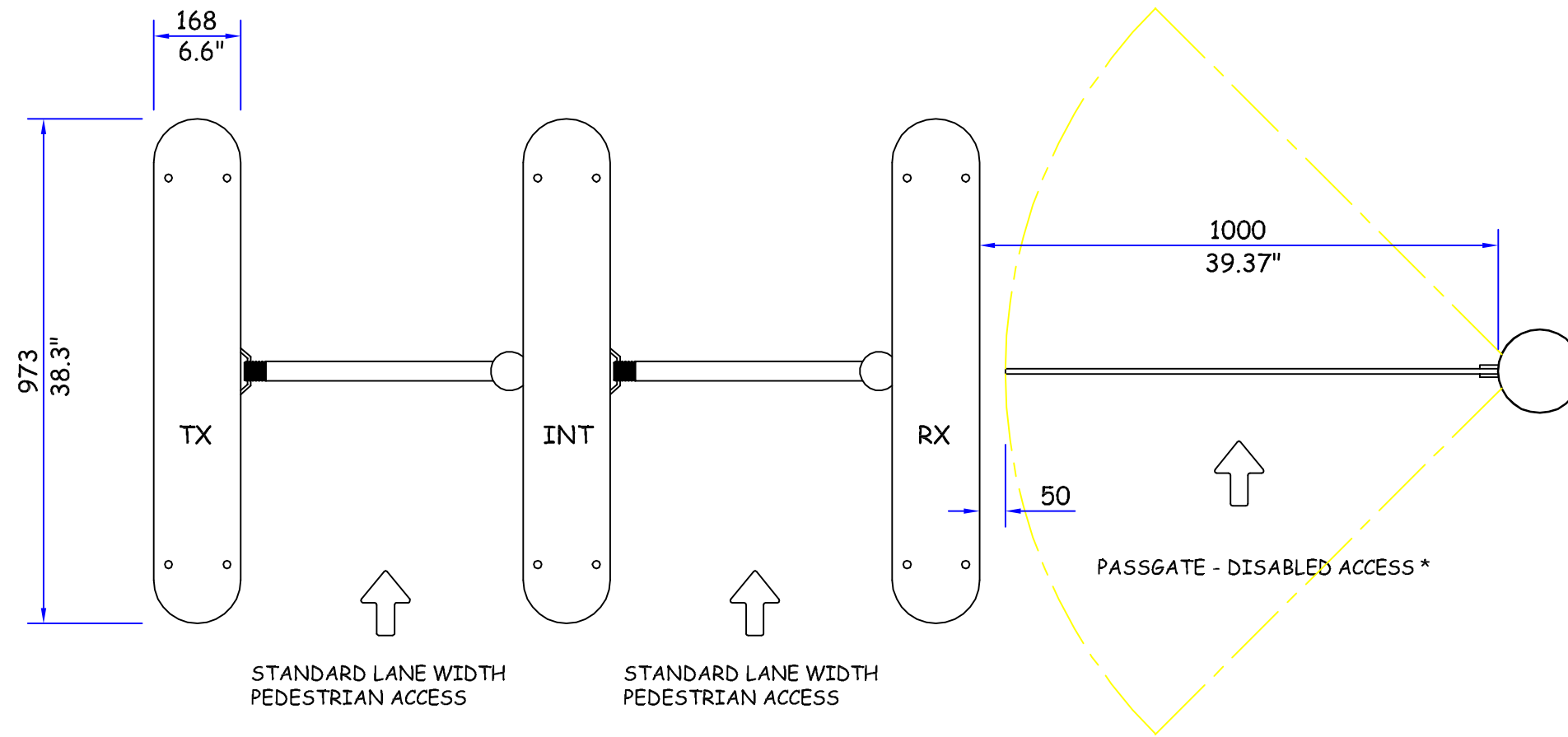

* SUBJECT TO LOCAL LEGISLATION

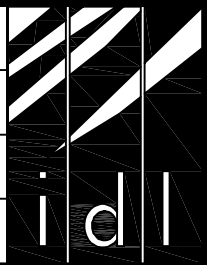
PRODUCT: FASTLANE PLUS R30		
TITLE: GENERAL LAYOUT		
DRAWN: DSC	DRAWING No: S665_523_A2	
DATE: 22.4.08	This document is the copyright of Integrated Design Ltd	

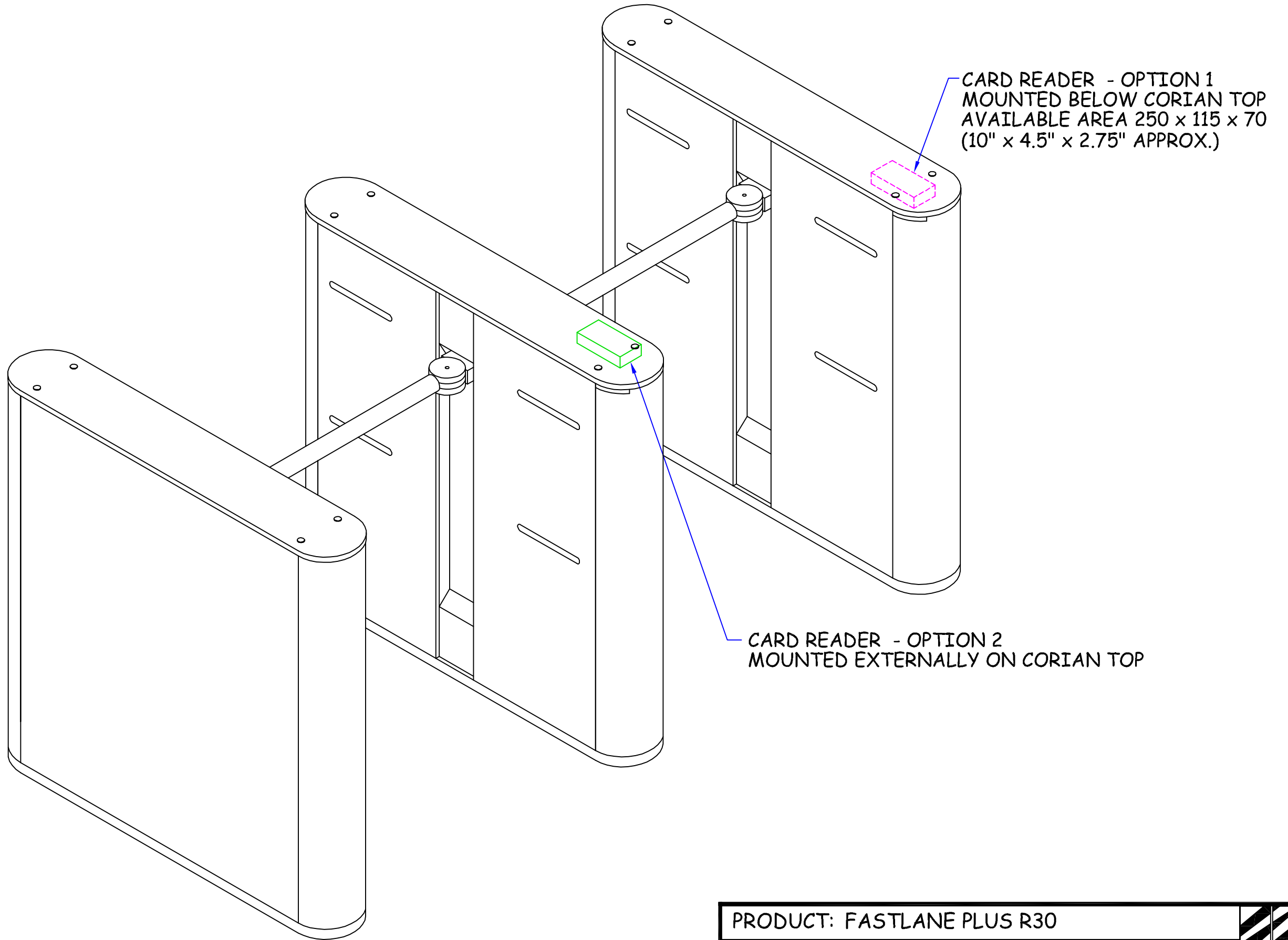

PRODUCT: FASTLANE PLUS R30	
TITLE: CARD READER OPTIONS	
DRAWN: DSC	DRAWING No: S665_524_A1
DATE: 22.4.08	This document is the copyright of Integrated Design Ltd

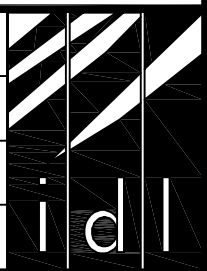

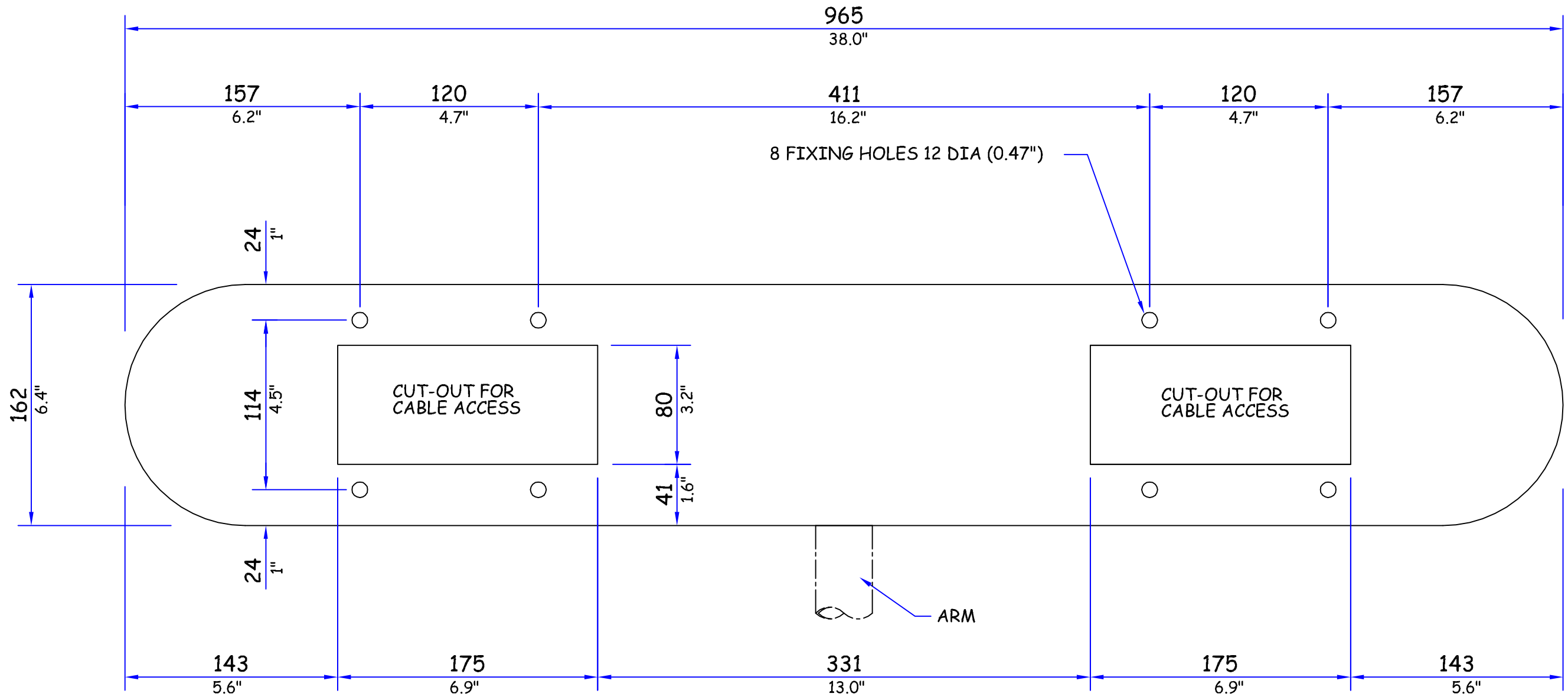

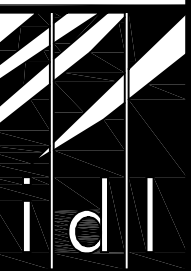

NOTE: UNIT IS TO BE SECURED TO THE FLOOR USING 10mm (0.39") DIA FIXINGS SUITABLE FOR THE FLOOR STRUCTURE.

PRODUCT: FASTLANE PLUS R30	
TITLE: BASE DRILLING TEMPLATE	
DRAWN: DSC	DRAWING No: S665_525_A0
DATE: 23.4.08	This document is the copyright of Integrated Design Ltd

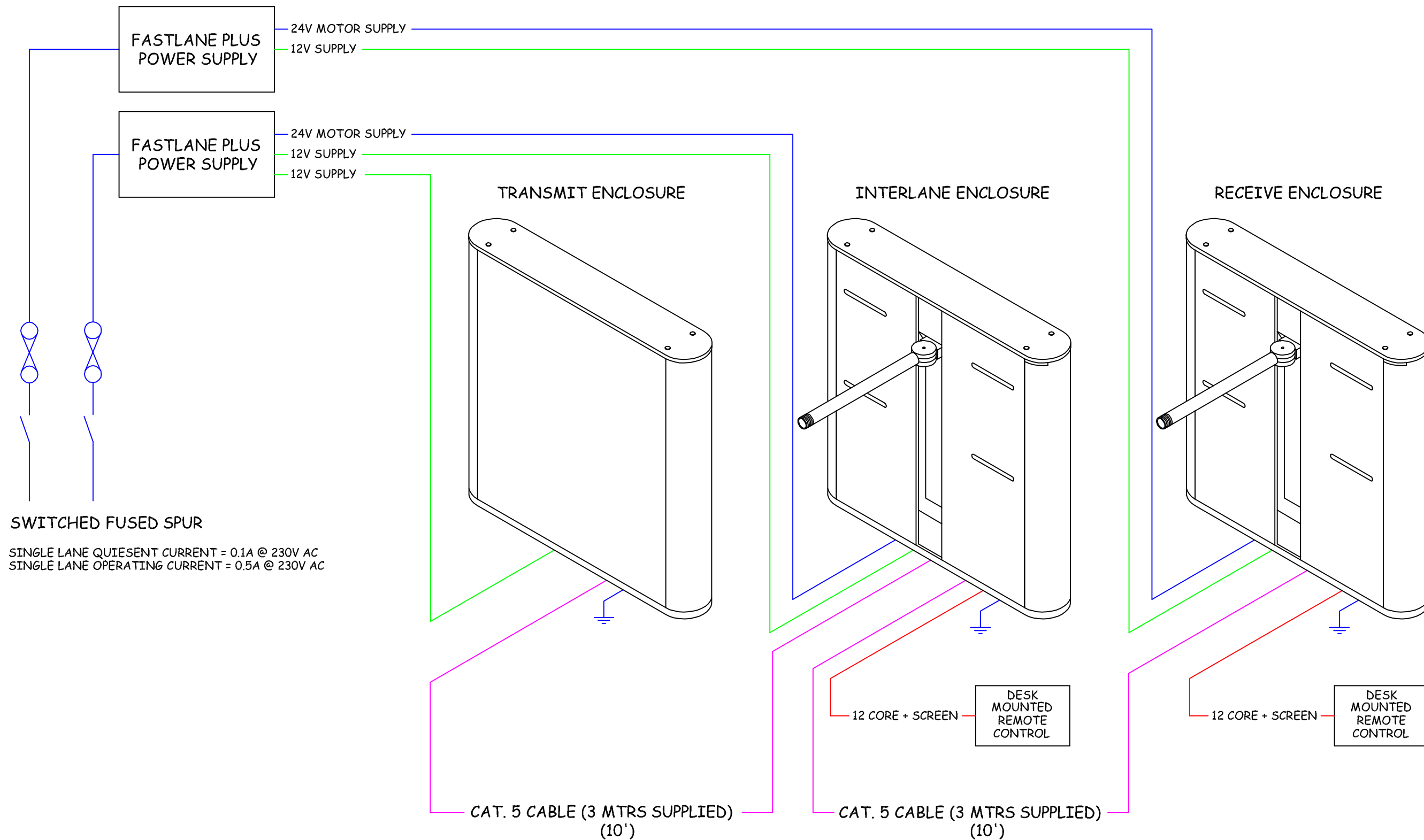



THIS DRAWING SHOWS THE FASTLANE PLUS CABLING REQUIREMENTS. IT IS TO BE READ IN CONJUNCTION WITH DRAWING 665_527_A1, WHICH SHOWS THE CABLING REQUIREMENTS FOR THE ACCESS CONTROL INTEGRATION. FOR FURTHER INFORMATION, REFER TO THE INSTALLATION MANUAL.

PRODUCT: FASTLANE PLUS R30		
TITLE: CABLING REQUIREMENTS		
DRAWN: DSC	DRAWING No: S665_526_A1	
DATE: 23.4.08	This document is the copyright of Integrated Design Ltd	

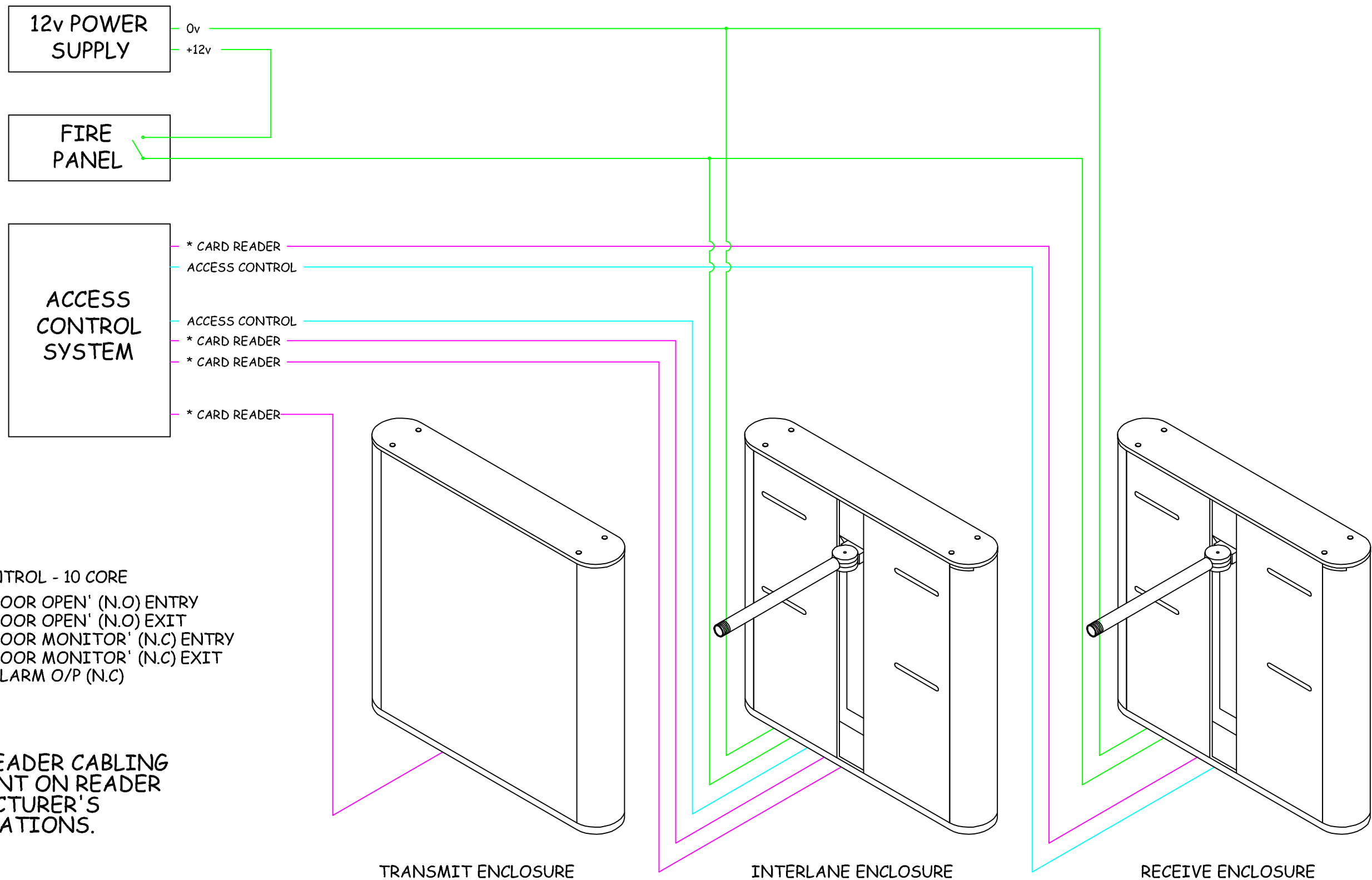

ACCESS CONTROL - 10 CORE

- <IP 'DOOR OPEN' (N.O) ENTRY
- IP> 'DOOR OPEN' (N.O) EXIT
- <ENT 'DOOR MONITOR' (N.C) ENTRY
- ENT> 'DOOR MONITOR' (N.C) EXIT
- AL1 ALARM O/P (N.C)

* CARD READER CABLING DEPENDENT ON READER MANUFACTURER'S SPECIFICATIONS.

THIS DRAWING SHOWS THE ACCESS CONTROL INTEGRATION REQUIREMENTS. IT IS TO BE READ IN CONJUNCTION WITH DRAWING 665_526_A1 WHICH SHOWS THE FASTLANE PLUS CABLING REQUIREMENTS.

FOR FURTHER INFORMATION, REFER TO THE INSTALLATION MANUAL.

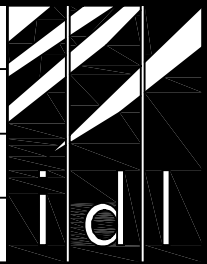
PRODUCT: FASTLANE PLUS R30		
TITLE: CABLING REQUIREMENTS		
DRAWN: DSC	DRAWING No: S665_527_A1	
DATE: 23.4.08	This document is the copyright of Integrated Design Ltd	