

# Fastlane *plus* Floor Protector

## Fastlane Floor Protector System

The Fastlane Floor Protector System is a modular system designed to support Fastlane pedestals without the need for drilling fixing bolts in to the floor or running a conduit under the floor between pedestals for cables.

The Floor Protector System is ideal for applications where the flooring materials used (such as marble, tiles, granites, etc) in the floor restrict drilling and cabling or where the building is Heritage Listed and any such works would be prohibited. Additionally the system is suited to temporary installations and sites where the tenants of a building are on a short-term lease and they do not want to affect the infrastructure of the building.

The Floor Protector System is available in an UK Disabilities Act version, where the angle and height of the ramp employed and the distances between the pedestals are in keeping with the UK Disabilities Act ensuring the system is wheelchair friendly.

The Floor Protector System allows for quick, efficient and cost effective installation of Fastlane optical turnstiles without damaging the floor of the building.

**Figure 1**

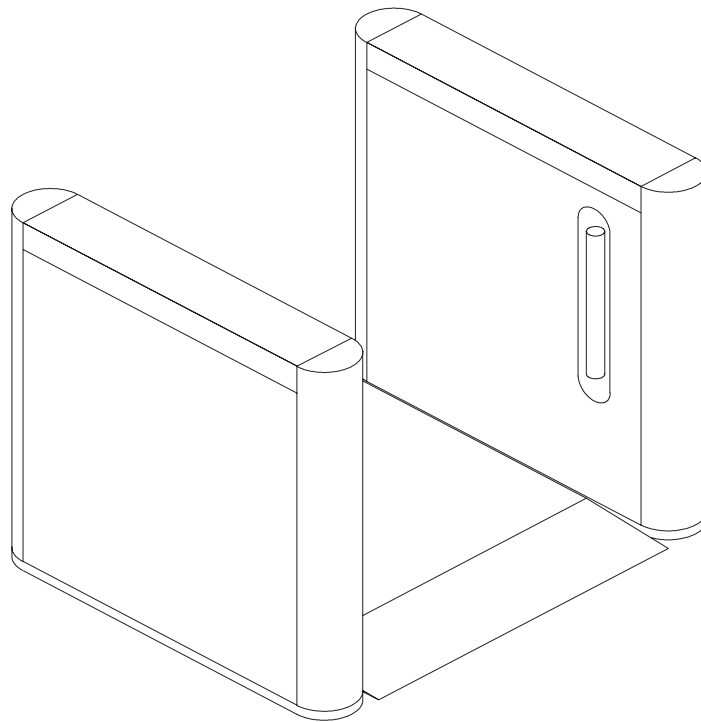

# Fastlane *plus* Floor Protector

## Base Options

There are 2 options

1. Standard Access Base
2. Disabled Access Base

## Mechanical Layout Drawing

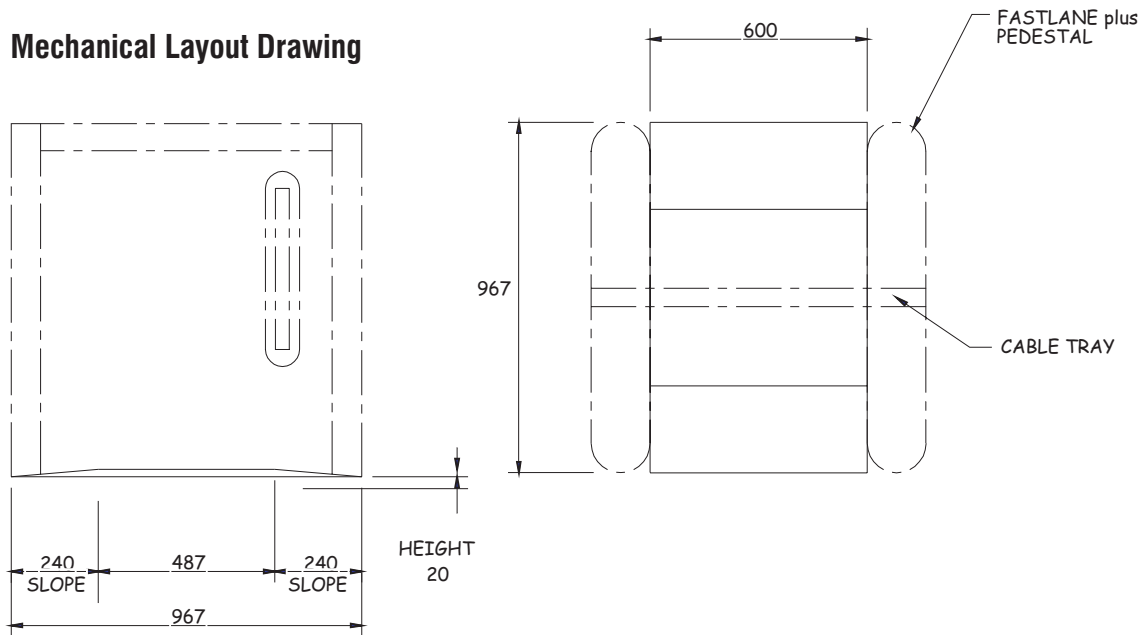

## Specifications

Base	
Max Height	20 mm
Slope angle	1 in 12
Lane Width	660 mm standard, 915 mm disabled
Length	967 mm for Fastlane <i>plus</i> Other options for other pedestals
Material	Mild Steel
Cable tray dims	50 mm * 15 mm
Colour	Black



Manufactured by:  
Integrated Design Ltd  
Littleton House  
Littleton Road  
Ashford  
Middlesex  
TW15 1UU, UK

Due to continued improvements specifications are subject to change with out prior notice

t: +44 (0) 1784 245 941  
f: +44 (0) 1784 240 647  
e: info@idl.co.uk  
w: www.idl.co.uk  
w: www.fastlane-turnstiles.com